

P420 Series Installation Guide

Wiring and Circuit Diagram

Model P420

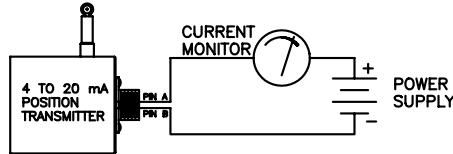

The 4 to 20 mA output transducer is a 2-wire, loop powered device. The transducer, power supply, and current monitor must be connected in series as illustrated above.

The minimum supply voltage is a function of total loop resistance. It may be calculated using the formula:

$$V(\text{Min.}) = (0.02 \times \text{Load Res.}) + 9 \text{ VDC}$$

It may also be determined from the accompanying graph, shown at right.

When mounting, insure that the baseplate of the transducer is grounded to earth ground. For best noise immunity, use twisted pair

shielded cable between the transducer and the electrical interface. The shield of the cable should be open at the transducer and grounded at the electrical interface.

With small blade type screwdriver (.105" max. Blade width X .023" max. blade thickness), adjust the Zero and Span controls on the transducer to set the 4 and 20 mA output limits. Note: The Zero and Span controls are somewhat interactive and may require several iterations to obtain the desired zero and maximum settings.

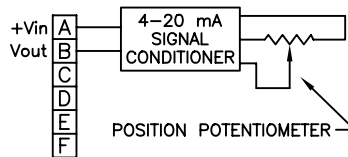

Excitation Voltage ..9 to 35 VDC
Total Loop resistance Per Graph

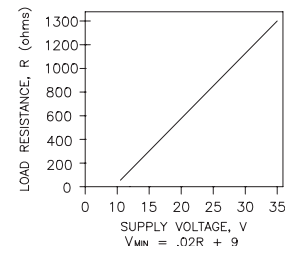

Extend the transducer's cable (on angular position transducers, rotate shaft) to the desired zero position (must be within 0% to 30% of range). Adjust the Zero control so that the output current is 4 mA. Then extend the cable (on angular position transducers, rotate shaft) to the desired maximum position (must be within 80% to 100% of range). Adjust the Span control for maximum output current of 20 mA. Recheck the zero setting and adjust if necessary. Recheck the Span setting and readjust if necessary.

Dimensional Information

Ranges to 50" (1250 mm)

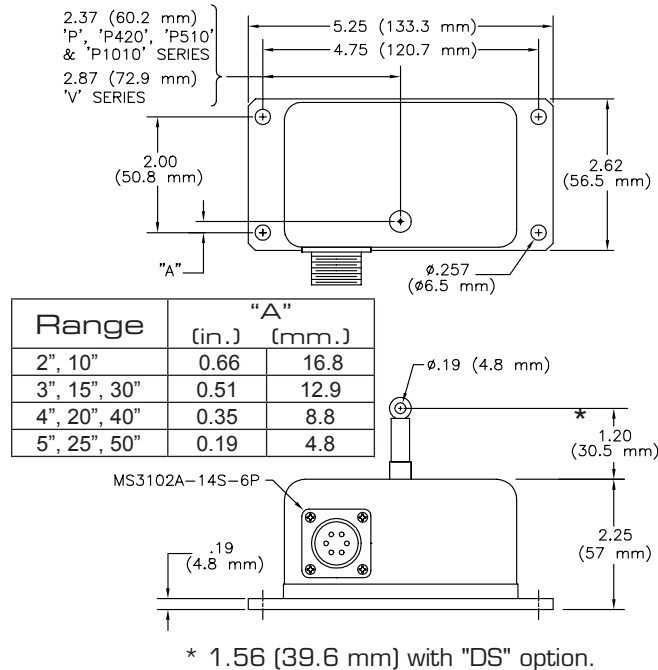

Ranges to 80" (2000 mm)

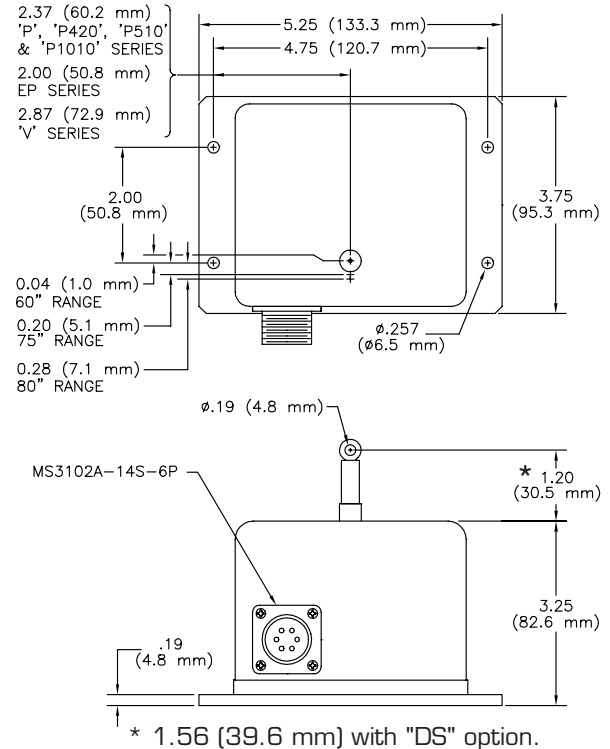

Standard Series Installation Guide

OPTION "CES" SIDE CABLE EXIT

PA, PB, P420, P510, P1010, EP, V, VP SERIES

RANGE	PA, PB, P420, P510, P1010 EP, V SERIES	
	DIMENSION "A"	DIMENSION "B"*
2", 10"	1.52" (38.6 mm)	1.28" (32.5 mm)
3", 15", 30"	1.68" (42.7 mm)**	1.28" (32.5 mm)
4", 20", 40"	1.84" (46.7 mm)**	1.28" (32.5 mm)
5", 25", 50"	1.97" (50.8mm)**	1.28" (32.5 mm)
60"	2.53" (64.3 mm)	1.78" (45.2 mm)
75"	2.76" (70.2 mm)	1.78" (45.2 mm)
80"	2.84" (72.2 mm)	1.78" (45.2 mm)

RANGE	VP SERIES	
	DIMENSION "A"	DIMENSION "B"*
2", 10"	1.58" (40.1 mm)	1.68" (42.7 mm)
3", 15", 30"	1.74" (44.2 mm)**	1.68" (42.7 mm)
4", 20", 40"	1.90" (48.3 mm)**	1.68" (42.7 mm)
5", 25", 50"	2.03" (52.3 mm)**	1.68" (42.7 mm)
60"	2.59" (65.8 mm)	1.68" (42.7 mm)
75"	2.82" (71.6 mm)	1.68" (42.7 mm)
80"	2.90" (73.7 mm)	1.68" (42.7 mm)

* With "DS" (dust shield) option, add 0.36" (9.1 mm) to "B" dimensions above.

** With "HG" (high wire rope tension) option, add 0.375" to dimension shown for 30", 40" and 50" measurement ranges only.

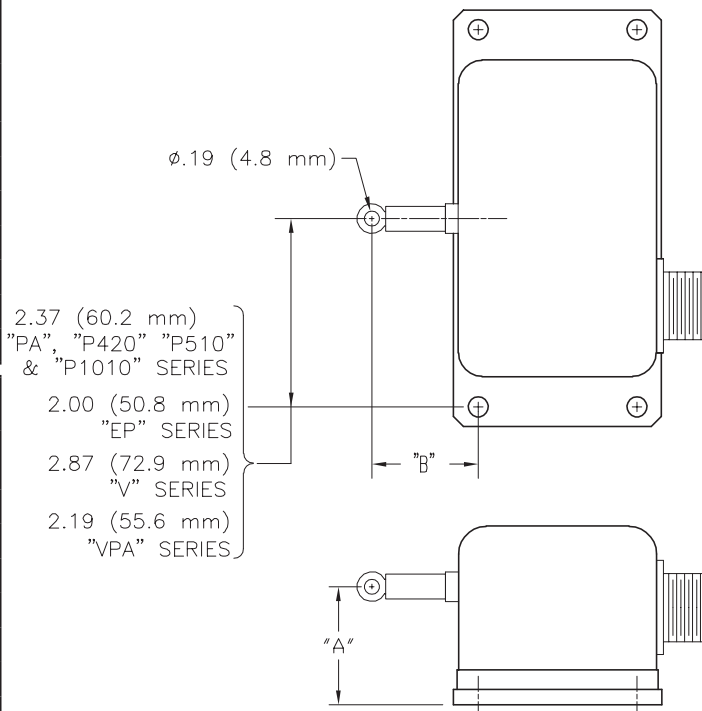

OPTION "CEB" BOTTOM CABLE EXIT

PA, PB, P420, P510, P1010, EP, V SERIES

RANGE	DIMENSION "A"
2", 10"	1.34 (34.0 mm)
3", 15", 30"	1.49 (37.8 mm)
4", 20", 40"	1.65 (41.9 mm)
5", 25", 50"	1.81 (46.0 mm)
60"	1.96 (49.8 mm)
75"	2.20 (55.9 mm)
80"	2.28 (57.9 mm)

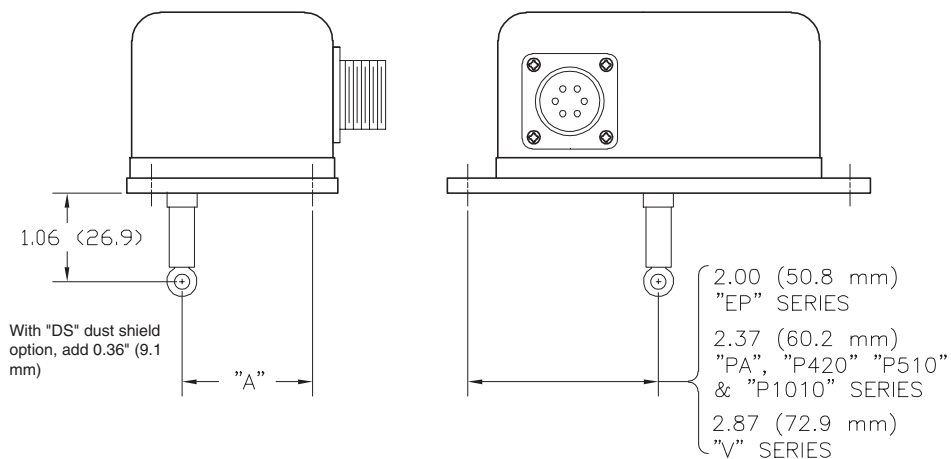

UniMeasure

4175 SW Research Way, Corvallis, Oregon, 97333

•Tel: (541) 757-3158 •Fax (541) 757-0858